



**ENCOURAGING
HENS TO LAY
IN THE NEST**

**AVIAGEN MANAGEMENT
ESSENTIALS**



INTRODUCTION

The occurrence of non-nest eggs (floor and slat eggs) will lead to increased labour requirements, reduced hatching egg quality due to excess contamination, and a potential reduction in hatch and chick quality. Understanding the reasons why eggs are laid outside the nests and what can be done to minimise them is important if chick output is to be maximised.

This article focuses on ways of minimising the incidence of non-nest eggs by examining methods of encouraging hens to lay eggs in the nest. The key to minimising non-nest eggs is early prevention and training, therefore management during rearing and pre-peak is critical.

REARING

Properly training hens to use the nests is vital if the incidence of non-nest eggs is to be reduced or avoided. Training should start early in the pullets' life with perches and platforms being provided in the rearing period to help train and stimulate the females in jumping and nesting behaviour (see Figure 1). Perches should be placed in the rearing pens from 28-42 days of age with 3cm of perch space per female being provided. Platforms can be used as an alternative or supplement to perches, allowing 1m² of platform for every 500 females. Ideally these 'training' perches/ platforms should be of the same design and material as those used in the laying house.

KEY POINT

Training of hens to use the nest should start early in rear, with the use of perches and/or platforms to stimulate jumping and nesting behaviour.

Figure 1: Examples of perches and platforms to be provided in rear

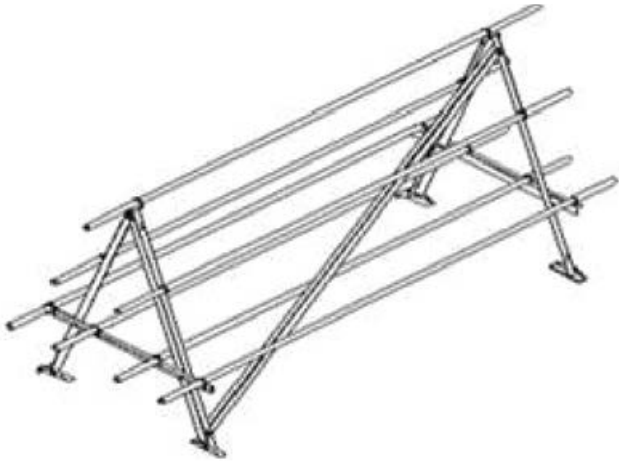

PRODUCTION

House preparation

It is important to make sure that all equipment, including the ventilation, feeder and drinker systems, is installed and operational prior to birds entering the house. With facilities that are day-old to depletion all production equipment, especially the nests, must be prepared well before the expected onset of production. The house should be prepared in accordance with best practice (see Ross Parent Stock Management Manual) to ensure maximum comfort and optimum production.

KEY POINT

Preparation of the house for lay should be completed prior to bird arrival to the house.

TRAINING BIRDS TO LAY EGGS IN NESTS

Once the house has been correctly set up, training birds to lay eggs in the nests is the single most effective way of preventing non-nest eggs. Females will begin to look to nest about one week before their first egg is laid.

During the laying period, slats and litter areas should be slowly walked a number of times throughout the day by the stockman. This may be the single most effective proactive management tool a stockman has to discourage hens from floor nesting and should start as soon as the birds are moved into the house. In walking around the house the aim is to look for any pullets that are attempting to establish nest sites out of the nest boxes. Pullets tend to look for nest sites early in the morning, so walking through the house at this time is critical for preventing floor eggs. Walking around the house 10-12 times during the morning is not considered too often.

Figure 2: Pullet nesting by solid wall



Pullets looking for alternative nest sites tend to be attracted to dark/shaded areas such as dark or solid walls, corners, the area next to steps and slat fronts and to the area under bell drinkers and nests (see Figure 2). Pullets attempting to establish nest sites should be gently picked up and placed in an empty nest.

Disturbing the birds that are trying to nest discourages them from using these sites. If the continued use of these 'alternative' nesting areas occurs, it may be necessary to fence birds from these areas with wire netting.

Where automated systems are used, the egg gathering belts should be run several times each day, even before obtaining the first egg, so that the pullets become acclimatised to the sound and vibration of the equipment. It is good practice to initially run egg gathering belts slowly in conjunction with the operation of the feeders. After several days the egg collection system should gradually be run more often, increasing to several times during the morning and afternoon.

Non-nest eggs should be gathered frequently as uncollected eggs encourage the laying of more eggs in the same area. Along with training hens to use the nests, the regular and rapid collection of any non-nest eggs that do occur is an essential tool for the reduction / elimination of eggs laid outside the nest boxes.

KEY POINT

- **Training birds to lay eggs in the nests is the single most effective way of discouraging non-nest eggs.**
- **During lay, the house should be walked slowly and often, to check for hens making nest sites outwith the nest boxes.**
- **If the use of alternative nesting areas continues, these areas should be fenced off.**
- **Any non-nest eggs that do occur should be gathered frequently.**

FEEDING AND WATERING

Feeder equipment can also affect the occurrence of non-nest eggs. For example, if pan feeders are set at the wrong height or are not winched up following feeding, hens can lay eggs underneath them, while trough feeders positioned at the incorrect height can become a barrier to the nests. To prevent hens from laying eggs under them, ideally feeders should be raised as soon as the feed is consumed. It is good practice to visit the flock at feeding time to monitor feeding progress and behaviour as many potential problems can be identified during such visits.

If a water control programme is employed, water should be made available to the flock at the same time, or slightly before, the lights are turned on in the morning. Water should be available throughout the feeding period, in most cases throughout the morning and should coincide with the most active laying period. If water is withheld at this time hens will be encouraged to lay eggs outside the intended nesting sites as they seek water.

Bell type drinkers should be maintained at a height that allows all birds to obtain water without providing potential protected nesting sites. Nipple systems minimise this problem, but if set too low, nipple lines can act as a barrier to the nests.

KEY POINT

- **Timing of feeding should not coincide with the most active laying period.**
- **Drinkers and feeders should be at a height that allows easy access to all birds without acting as a barrier to the nests or providing protected nest sites.**

NEST MANAGEMENT

Birds should be housed according to the capacity of the equipment and the available floor space and not on available floor space alone. The number of hens per nest is critical for minimising the number of non-nest eggs.

No more than 40 females per linear meter should be placed for mechanical (communal type) nests and a maximum of 4 hens per nest hole for manual nests. Exceeding these recommendations will greatly increase the incidence of non-nest eggs, especially during the onset of production and during the peak production period. The alighting rail for the lower tier of nests should not be more than 55cm above the litter. The bottom tier alighting rail should extend to a minimum of 10cm beyond the second tier rail. Figures 3 & 4 show good set ups for manual and mechanical systems.

Figure 3:
Example of a good manual nest system



Figure 4:
Example of a good automated nest



Nests should be made attractive to young hens and nest cleanliness is an important part of this. Nests must be in good repair with sound, solid bottoms and fresh, clean, dry bedding material. Fouled nests will discourage hens from using them and dirty nests should be cleaned.

Egg gathering belts should be kept clean throughout the production period and at the very least be cleaned and sanitised between flocks.

Nest units should be securely positioned and should not rock or move when hens enter or leave the unit. Perches need to be in good repair and structurally strong enough to support the weight of several birds at once.

KEY POINT

- Do not over-crowd nests.
- Nest should be clean, comfortable and well maintained.
- Maintain the cleanliness of the egg gathering belts in mechanical systems.

SLAT MANAGEMENT

Slat height is critical, especially with yield type hens. Slat height with mechanical egg gathering systems should be 45-50cm high. The actual slat height will be dependant on the flock's depletion age and litter height. With higher slats, a ramp to aid hens in accessing the nests should be provided.

Where nests are located on the slatted area, the nests should be located 30-36cm from the edge of the slats. The incline from the front of the slats to the nest box should be around five degrees and not exceeding 10 degrees. The perch height of conventional manual egg gathering systems is slightly less critical and may be increased up to a maximum of 55cm. If slats are lower than this, birds may be encouraged to nest under them. Manual nests should be constructed to eliminate the more attractive dark space under the nests either by fencing off the area under the nests or through the provision of additional lighting.

Where automatic nest boxes are used, house litter levels should be maintained at 5-8cm deep to discourage birds from digging deep comfortable holes in which to lay eggs.

KEY POINT

- In mechanical egg gathering systems slat height should be between 45cm and 50cm.
- In manual systems perch height should not exceed 55cm.
- Nest holes should be easily accessed by the birds.
- Manual nests should be constructed to eliminate the dark space underneath them, by fencing off these areas or through the provision of additional lighting.

OTHER

LIGHTING MANAGEMENT

Light should be evenly distributed throughout the house and be of the correct intensity (light intensity should be uniformly increased from approximately 10 lux in the rearing period to 60 lux in production) if floor eggs are to be minimised. Darkened areas of the house provide an enticing area for birds to lay eggs. It is therefore vital that shadows or poorly lit areas are reduced or eliminated, if females are to be encouraged to lay eggs in the nests.

It may be necessary to install extra lights over the slats, in front of the air inlet pad areas in evaporative pad cooling equipped houses and under manual egg collection nests, to discourage hens from laying eggs in these normally problematic areas.

KEY POINT

Eliminate/reduce shadows in the production house by providing evenly distributed light of the correct intensity.

TEMPERATURES - VENTILATION

Hen house temperature/ventilation will have a significant influence on inducing hens to use nests. Ventilation systems should be adjusted to control temperatures between 18 & 24 °C.

Housing and nest temperatures in excess of, or below, the recommended range can cause birds to avoid the nests. Proper uniform tunnel-ventilated housing with the effective use of evaporative cooling will help encourage hens to use nests in warm periods. In the winter it is important to ensure that cold incoming air is not directed into the nests as this will also discourage hens from laying in them. For the same reason fans and fogging systems should not blow forcibly and directly into the nests.

KEY POINT

If the nest conditions are uncomfortable hens will locate to more favourable sites and non-nest eggs will be increased.

CONCLUSION

There are no easy answers for reducing the occurrence of floor or slat (non-nest) eggs. A low incidence of non-nest eggs early in a flocks' life can be corrected in most cases as the flock gets older and hens lay more in the nests. However, flocks with more extreme floor/slat egg problems will continue to be problem flocks throughout the laying period.

It is therefore essential that effort is put into preventing the occurrence of non-nest eggs early on in a life of a flock. The key to achieving this is training; the extra effort of planning, prevention and early training of pullets to lay eggs in the nests, although not one hundred percent, is the only real means of ensuring a high percentage of nest-laid eggs.



WORLD'S NO.1 BROILER BRAND

T: +27 (0) 16 366 0249

www.rosspoultrybreeders.co.za

Block A, Techno Link Office Park,
63 Regency Drive, Route 21 Business Park, Irene.
Republic of South Africa

P.O.Box 297
Meyerton 1960
Republic of South Africa

